

SPECIFICATION
FOR
LCM Module

MODULE No:	KD035QHFPD154
CUSTOMER:	

STARTEK	INITIAL	DATE
PREPARED BY		
CHECKED BY		
APPROVED BY		

CUSTOMER	INITIAL	DATE
APPROVED BY		

Revision History

Date	Rev. No.	Page	Summary
2020.11.06	V1.0	ALL	FIRST ISSUE
2020.12.29	V1.1	6/13	Update the drawing and LED Backlight Characteristics

Contents

1. Block Diagram		5
2. Outline dimension.....		6
3. Input terminal Pin Assignment		7
4. LCD Optical Characteristics.....		9
4.1 Optical specification.....		9
5. Electrical Characteristics		12
5.1 Absolute Maximum Rating.....		12
5.2 DC Electrical Characteristics		12
5.3 LED Backlight Characteristics		13
6. AC Characteristics.....		15
6.1 Serial interface characteristics (SPI).....		15
6.2 RGB Interface Selection		16
6.3 RGB Interface Timing		18
6.4 Parallel 24/18/16-bit RGB Interface Timing Characteristics		21
7. LCD Module Out-Going Quality Level.....		22
7.1 VISUAL & FUNCTION INSPECTION STANDARD		22
7.1.1 Inspection conditions		22
7.1.3 Sampling Plan		23
7.1.4 Criteria (Visual).....		24
8. Reliability Test Result		28
9. Cautions and Handling Precautions.....		29
9.1 Handling and Operating the Module		29
9.2 Storage and Transportation.		29
10. Packing.....		30

Part. No	KD035QHFPD154	REV	V1.1	Page 3 of 30
	常备库存 Stock For Sale	长期供货 Long Time supply	支持小量 NO MOQ	品种齐全 In Full Range

*** Description**

This is a color active matrix TFT (Thin Film Transistor) LCD (liquid crystal display) that uses amorphous silicon TFT as a switching device. This module is composed of a Transmissive type TFT-LCD Panel, driver circuit, back-light unit. The resolution of a 3.54 " TFT-LCD contains 640x960 pixels, and can display up to 16.7M colors.

*** Features**

General Information Items	Specification	Unit	Note
	Main Panel		
Display area(AA)	49.92(H)*74.88(V) (3.54 inch)	mm	
Driver element	TFT active matrix	-	
Display colors	65K/262K/16.7M	colors	
Number of pixels	640(RGB)*960	dots	
Pixel arrangement	RGB vertical stripe	-	
Pixel pitch	0.078(H)*0.078(V)	mm	
Viewing angle	Free	o'clock	
Controller IC	NV3052CGRB	-	
LCM Interface	3SPI+16/18/24BIT RGB	-	
Display mode	Transmissive /Normally Black	-	
Operating temperature	-30~+85	°C	
Storage temperature	-30~+85	°C	

*** Mechanical Information**

Item		Min.	Typ.	Max.	Unit	Note
Module size	Horizontal(H)	-	54.58	-	mm	Without hook
	Vertical(V)	-	84.42	-	mm	Without hook
	Depth(D)	-	2.55	-	mm	
Weight		-	25	-	g	

Part. No	KD035QHFPD154	REV	V1.1	Page 4 of 30
常备库存 Stock For Sale	长期供货 Long Time supply	支持小量 NO MOQ	品种齐全 In Full Range	

1. Block Diagram

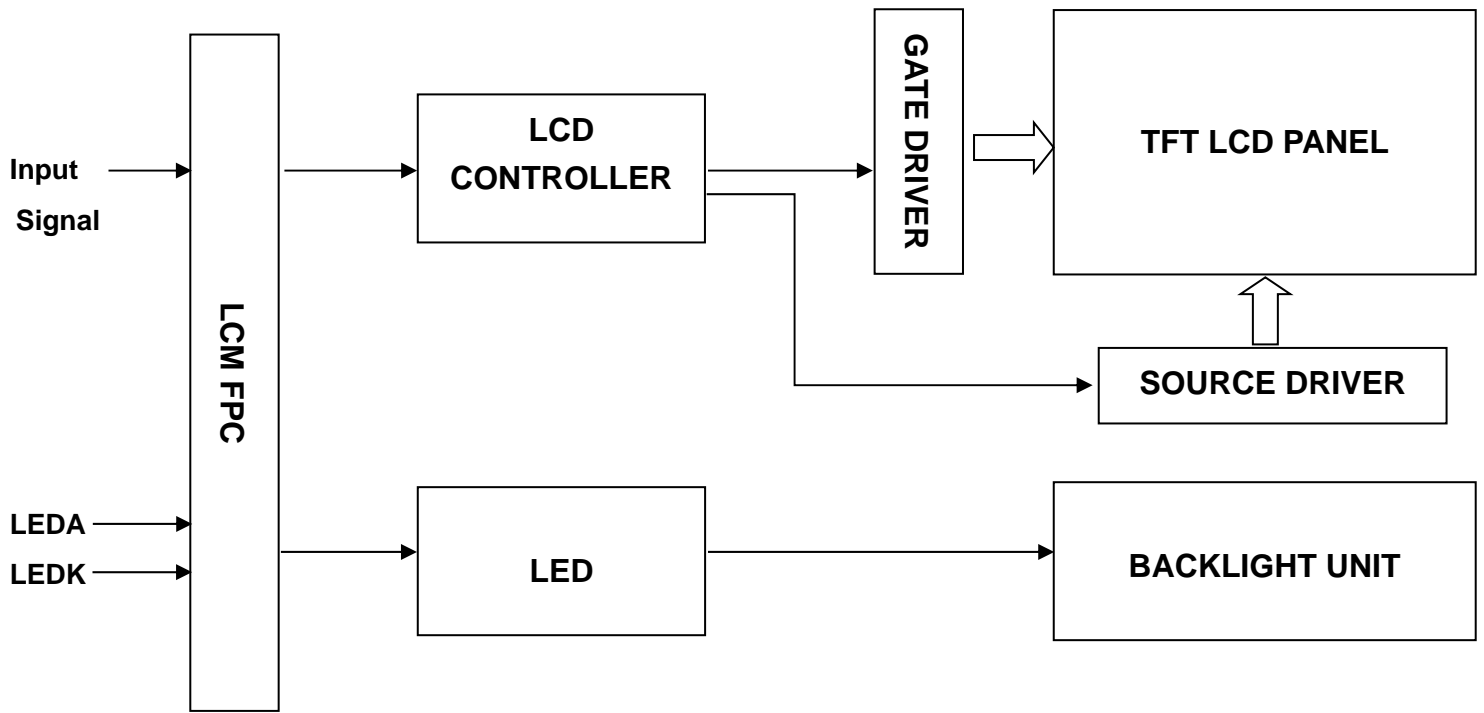

Part. No	KD035QHFPD154	REV	V1.1	Page 5 of 30
常备库存 Stock For Sale	长期供货 Long Time supply	支持小量 NO MOQ	品种齐全 In Full Range	

2. Outline dimension

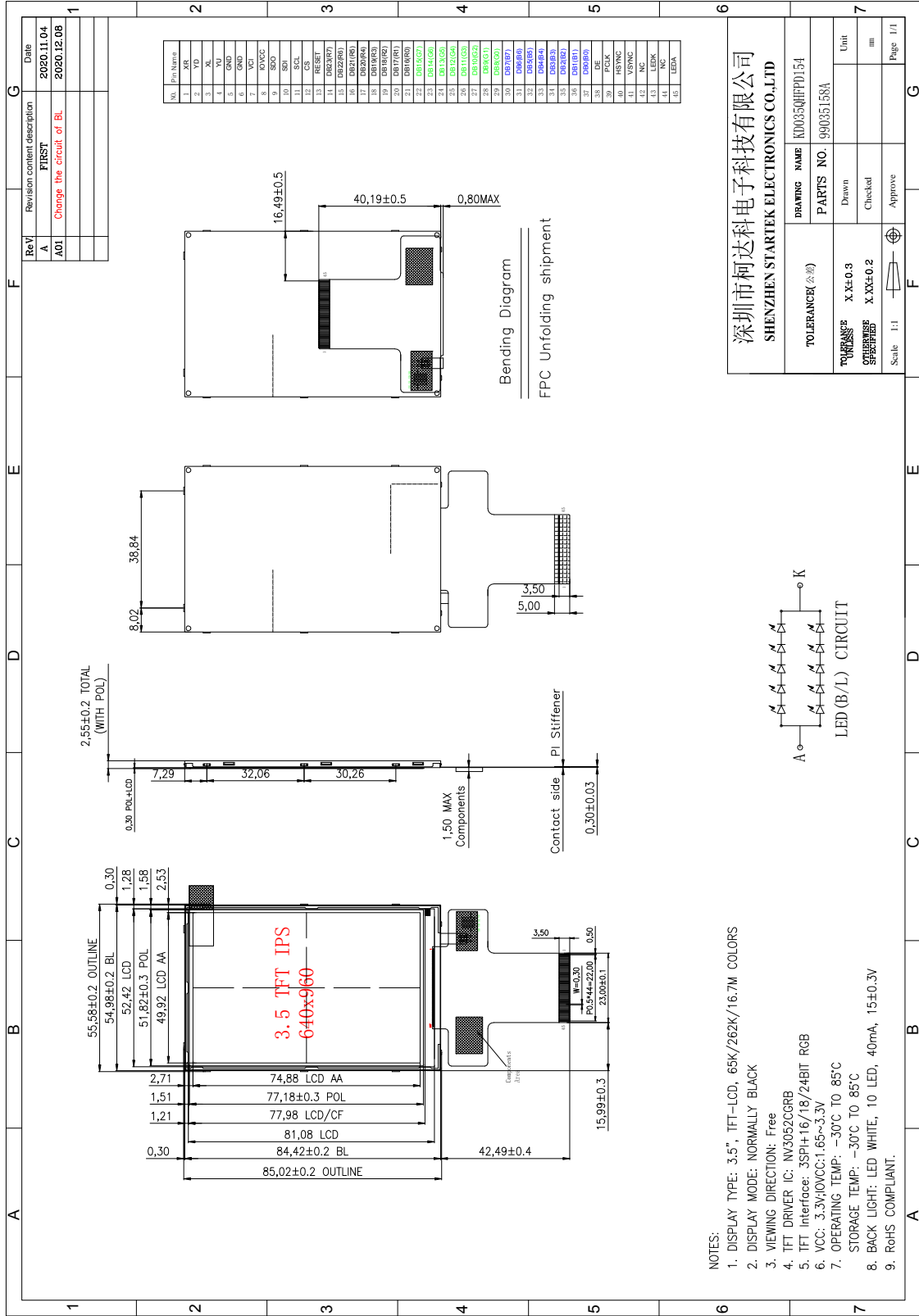

Part. No	KD035QHFPD154	REV	V1.1	Page 6 of 30
常备库存 Stock For Sale	长期供货 Long Time supply	支持小量 NO MOQ	品种齐全 In Full Range	

3. Input terminal Pin Assignment

NO.	SYMBOL	DISCRIPTION	I/O
1	XR(NC)	Touch panel Right Glass Terminal	A/D
2	YD(NC)	Touch panel Bottom Film Terminal	A/D
3	XL(NC)	Touch panel LIFT Glass Terminal	A/D
4	YU(NC)	Touch panel Top Film Terminal	A/D
5	GND	Ground.	P
6	GND	Ground.	P
7	VCI	Supply voltage (3.3V).	P
8	IOVCC	I/O power supply voltage.	P
9	SDO	SPI interface output pin.-The data is output on the falling edge of the SCL signal.-If not used, let this pin open.	O
10	SDI	Data lane in 1 data lane serial interface. The data is latched on the rising edge of the SCL signal.	I
11	SCL	This pin is used serial interface clock in 3-wire 9-bit serial data interface. fix this pin at VCI or GND when not in use.	I
12	CS	Chip select input pin ("Low" enable). fix this pin at VCI or GND when not in use.	I
13	RESET	Reset pin. Setting either pin low initializes the LSI. Must be reset after power is supplied.	I
14-37	DB23-DB0	24-bit parallel bi-directional data bus for MCU system and RGB interface mode .Fix to GND level when not in use	I/O
38	DE	Data enable signal for RGB interface peration. fix this pin at VCI or GND when not in use.	I
39	DOTCLK	Dot clock signal for RGB interface operation. Fix this pin at VCI or GND when not in use.	I
40	HSYNC	Line synchronizing signal for RGB interface operation. fix this pin at VCI or GND when not in use.	I
41	VSYNC	Frame synchronizing signal for RGB interface operation. fix this pin at VCI or GND when not in use.	I
42	NC		

Part. No	KD035QHFPD154	REV	V1.1	Page 7 of 30
常备库存 Stock For Sale	长期供货 Long Time supply	支持小量 NO MOQ	品种齐全 In Full Range	

43	LEDK	Cathode pin of backlight.	P
44	NC		
45	LEDA	Anode pin of backlight.	P

4. LCD Optical Characteristics

4.1 Optical specification

Item	Symbol	Condition	Min.	Typ.	Max.	Unit.	Note
Contrast Ratio	CR	$\Theta=0$	800	1000	--		(1)(2)
Response time	Rising	Normal viewing angle	--	35	40	msec	(1)(3)
	Falling						
Color Gamut	S(%)		65	70	--	%	
Color Filter Chromacity	White	W_x	0.2440	0.2840	0.3240		(1)(4)
		W_y	0.2830	0.3230	0.3630		
	Red	R_x	0.5935	0.6335	0.6735		
		R_y	0.3035	0.3435	0.3835		
	Green	G_x	0.2550	0.2950	0.3350		
		G_y	0.5345	0.5745	0.6145		
	Blue	B_x	0.1045	0.1445	0.1845		
		B_y	0.0273	0.0673	0.1073		
Viewing angle	Hor.	Θ_L	--	85	--		(1)(4)
		Θ_R	--	85	--		
	Ver.	Θ_U	--	85	--		
		Θ_D	--	85	--		
Option View Direction	Free						

*The data comes from the LCD specification.

Measuring Condition

Measuring surrounding : dark room

Ambient temperature : $25 \pm 2^\circ\text{C}$

15min. warm-up time.

Measuring Equipment

FPM520 of Westar Display technologies, INC., which utilized SR-3 for Chromaticity and BM-5A for other optical characteristics.

Part. No	KD035QHFPD154	REV	V1.1	Page 9 of 30
常备库存 Stock For Sale	长期供货 Long Time supply	支持小量 NO MOQ	品种齐全 In Full Range	

Note (1): Definition of Viewing Angle :

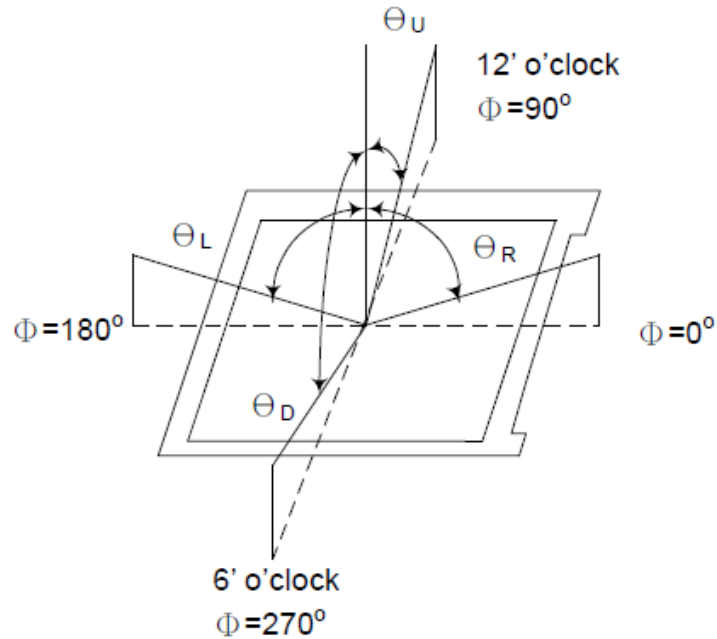

Note (2): Definition of Contrast Ratio(CR) :measured at the center point of panel

$$CR = \frac{\text{Luminance with all pixels white}}{\text{Luminance with all pixels black}}$$

Note (3): Response Time

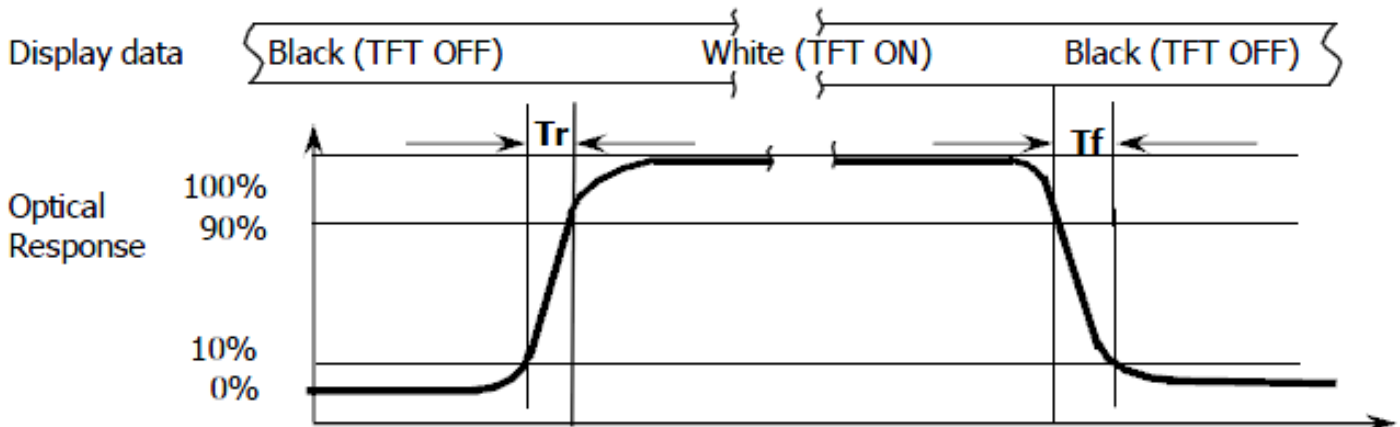

Part. No	KD035QHFPD154	REV	V1.1	Page 10 of 30
常备库存 Stock For Sale	长期供货 Long Time supply	支持小量 NO MOQ	品种齐全 In Full Range	

Note (4): Definition of optical measurement setup

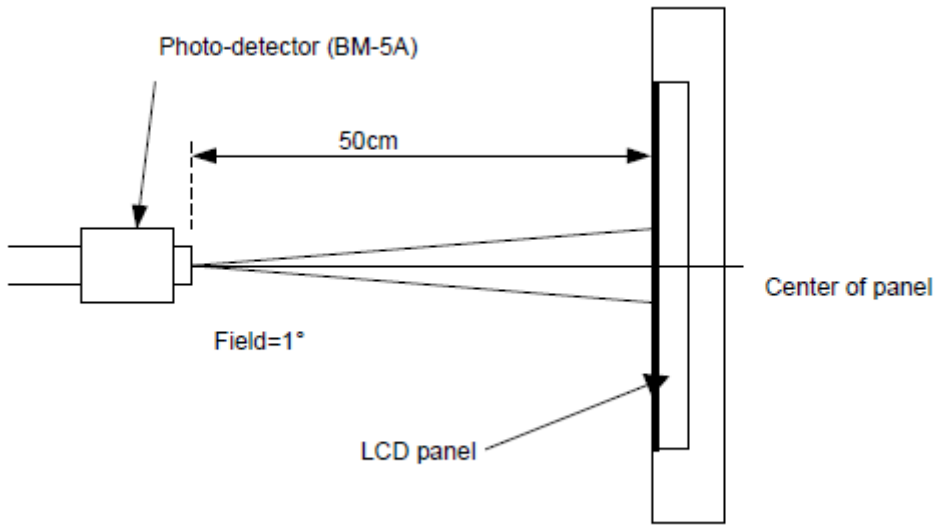

Part. No	KD035QHFPD154	REV	V1.1	Page 11 of 30
常备库存 Stock For Sale	长期供货 Long Time supply	支持小量 NO MOQ	品种齐全 In Full Range	

5. Electrical Characteristics

5.1 Absolute Maximum Rating

Characteristics	Symbol	Min.	Max.	Unit	Note
Digital Supply Voltage	V _{CI}	-0.3	6.6	V	Note1
Digital interface supply Voltage	IOVCC	-0.3	4.5	V	Note1
Operating temperature	T _{OP}	-30	+85	°C	
Storage temperature	T _{ST}	-30	+85	°C	

NOTE1: If the absolute maximum rating of even is one of the above parameters is exceeded even momentarily, the quality of the product may be degraded. Absolute maximum ratings, therefore, specify the values exceeding which the product may be physically damaged. Be sure to use the product within the range of the absolute maximum ratings.

5.2 DC Electrical Characteristics

Characteristics	Symbol	Min.	Typ.	Max.	Unit	Note
Digital Supply Voltage	V _{CI}	2.5	3.3	3.6	V	
Digital interface supply Voltage	IOVCC	1.65	1.8	3.6	V	
Normal mode Current	I _{VCI}	--	96	120	mA	
Level input voltage	V _{IH}	0.7*IOVCC	--	IOVCC+0.3	V	
	V _{IL}	GND-0.3	--	0.3*IOVCC	V	
Level output voltage	V _{OH}	IOVCC-0.4	--	--	V	
	V _{OL}	GND	--	GND+0.4	V	

Part. No	KD035QHFPD154	REV	V1.1	Page 12 of 30
----------	---------------	-----	------	---------------

常备库存
Stock For Sale

长期供货
Long Time supply

支持小量
NO MOQ

品种齐全
In Full Range

5.3 LED Backlight Characteristics

The back-light system is edge-lighting type with 10 chips LED

Item	Symbol	Min.	Typ.	Max.	Unit	Note
Forward Current	I_F	35	40	--	mA	
Forward Voltage	V_F	--	15	--	V	
LCM Luminance	LV	450	500	--	cd/m ²	Note3
LED life time	Hr	--	50000	--	Hour	Note1,2
Uniformity	Avg	80	--	--	%	Note3

Note1: LED life time (Hr) can be defined as the time in which it continues to operate under the condition:

$T_a=25\pm3\text{ }^\circ\text{C}$, typical IL value indicated in the above table until the brightness becomes less than 50%.

Note 2: The “LED life time” is defined as the module brightness decrease to 50% original brightness at

$T_a=25\text{ }^\circ\text{C}$ and $I_L=40\text{mA}$. The LED lifetime could be decreased if operating I_L is larger than 40mA. The constant current driving method is suggested.

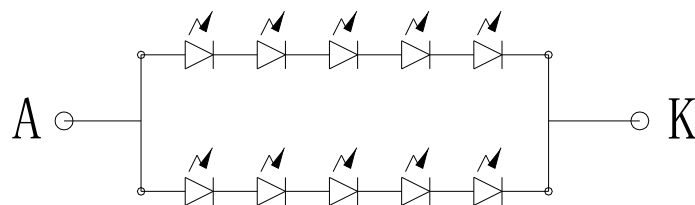

LED (B/L) CIRCUIT

Part. No	KD035QHFPD154	REV	V1.1	Page 13 of 30
常备库存 Stock For Sale	长期供货 Long Time supply	支持小量 NO MOQ	品种齐全 In Full Range	

Note (3) Luminance Uniformity of these 9 points is defined as below:

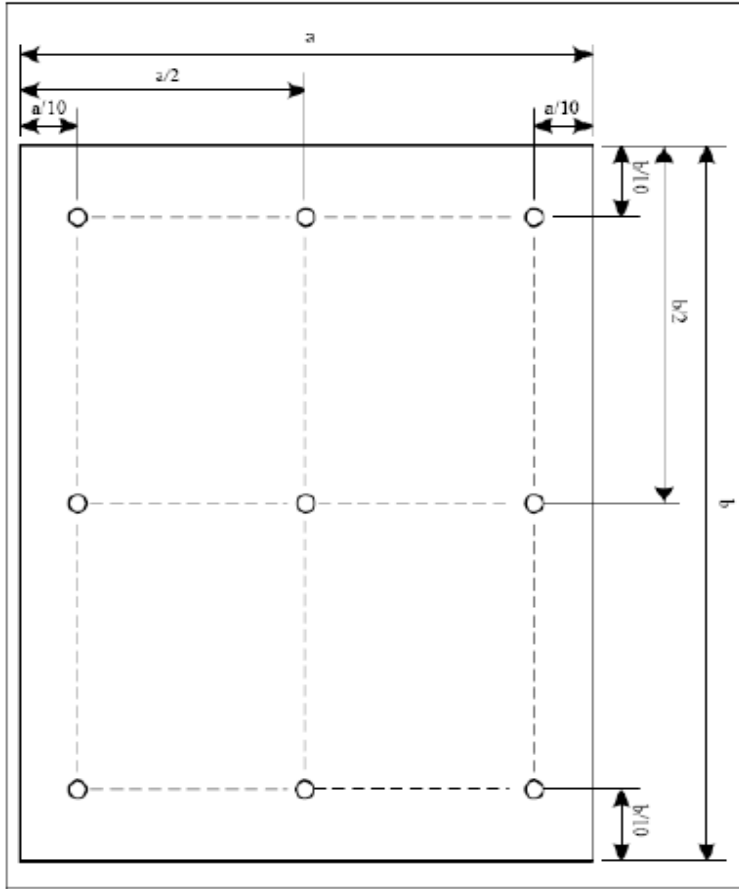

$$\text{Uniformity} = \frac{\text{minimum luminance in 9 points (1-9)}}{\text{maximum luminance in 9 points (1-9)}}$$

$$\text{Luminance} = \frac{\text{Total Luminance of 9 points}}{9}$$

Part. No	KD035QHFPD154	REV	V1.1	Page 14 of 30
常备库存 Stock For Sale	长期供货 Long Time supply	支持小量 NO MOQ	品种齐全 In Full Range	

6. AC Characteristics

6.1 Serial interface characteristics (SPI)

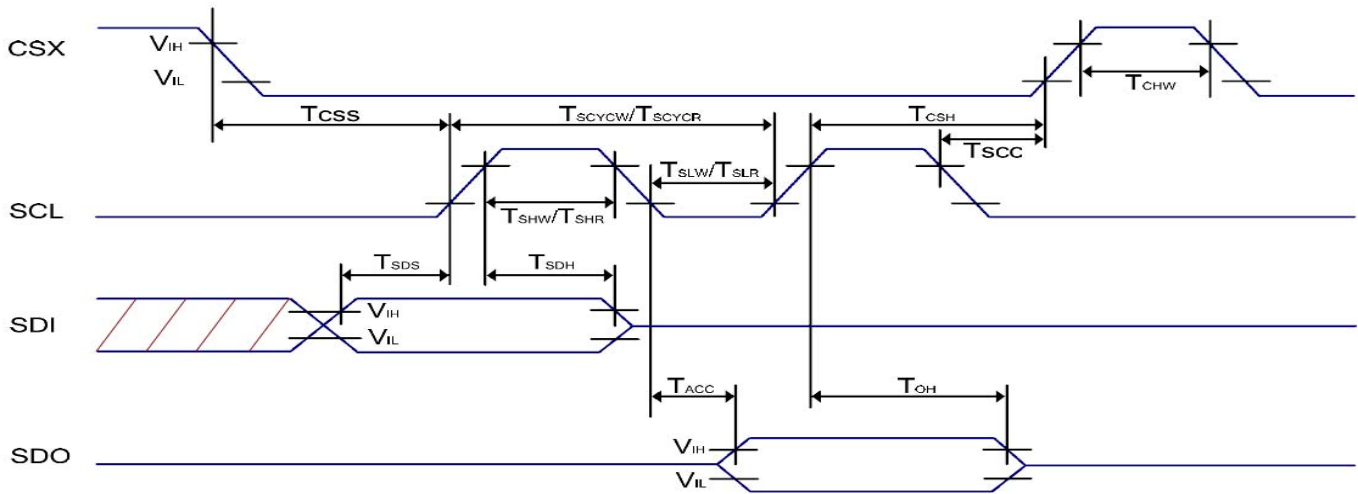

Figure: 3-pin Serial Interface Characteristics

Table: SPI Interface Characteristics

Signal	Symbol	Parameter	MIN	MAX	Unit	Description
CSX	T_{CSS}	Chip select setup time	15	-	ns	-
	T_{CSH}	Chip select hold time	15	-	ns	
	T_{SCC}	Chip select setup time	20	-	ns	
	T_{CHW}	Chip "H" pulse width	40	-	ns	
SCL	T_{SCYCW}	Serial clock cycle (Write)	66	-	ns	-
	T_{SHW}	SCL "H" pulse width (Write)	10	-	ns	
	T_{SLW}	SCL "L" pulse width (Write)	10	-	ns	
	T_{SCYCR}	Serial clock cycle (Read)	150	-	ns	-
	T_{SHR}	SCL "H" pulse width (Read)	60	-	ns	
	T_{SLR}	SCL "L" pulse width (Read)	60	-	ns	
SDI	T_{SDS}	Data setup time	10	-	ns	For maximum $C_L=30pF$ For minimum $C_L=8pF$
	T_{SDH}	Data hold time	10	-	ns	
	T_{ACC}	Access time	10	50	ns	
	T_{OH}	Output disable time	15	50	ns	

Note 1: $IOVCC=1.65$ to $3.6V$, $V_{CI}=2.5$ to $6V$, $V_{SSA}=V_{SS}=0V$, $T_a=-30$ to $70^\circ C$

Note 2: The rise time and fall time (t_r , t_f) of input signal is specified at 15 ns or less. Logic high and low levels are specified as 30% and 70% of $IOVCC$ for Input signals.

Part. No	KD035QHFPD154	REV	V1.1	Page 15 of 30
常备库存 Stock For Sale	长期供货 Long Time supply	支持小量 NO MOQ	品种齐全 In Full Range	

6.2 RGB Interface Selection

The RGB interface is operated with VS, HS, DE, PCLK, D[23:0] lines. It supports several pixel formats that can be selected by dpi [2:0] bits in "Interface Pixel Format (R3Ah)" of Page 0 command. The selection of a given interface is defined by dpi [2:0] as show in the below table.

RGB Interface Selection

dpi[2:0]			RGB Interface Mode	Used Pins
1	0	1	16-bit RGB interface	VS, HS, DE, PCLK, D[20:16], D[13:8], D[4:0]
1	1	0	18-bit RGB interface	VS, HS, DE, PCLK, D[21:16], D[13:8], D[5:0]
1	1	1	24-bit RGB interface	VS, HS, DE, PCLK, D[23:0]
Others			Setting prohibited	

16-bit DPI interface connection: set pixel format DPI[2:0]=3'h5

DB23	DB22	DB21	DB20	DB19	DB18	DB17	DB16	DB15	DB14	DB13	DB12	DB11	DB10	DB9	DB8	DB7	DB6	DB5	DB4	DB3	DB2	DB1	DB0	
			R[4]	R[3]	R[2]	R[1]	R[0]			G[5]	G[4]	G[3]	G[2]	G[1]	G[0]					B[4]	B[3]	B[2]	B[1]	B[0]

18-bit DPI interface connection: set pixel format DPI[2:0]=3'h6

DB23	DB22	DB21	DB20	DB19	DB18	DB17	DB16	DB15	DB14	DB13	DB12	DB11	DB10	DB9	DB8	DB7	DB6	DB5	DB4	DB3	DB2	DB1	DB0		
			R[5]	R[4]	R[3]	R[2]	R[1]	R[0]			G[5]	G[4]	G[3]	G[2]	G[1]	G[0]				B[5]	B[4]	B[3]	B[2]	B[1]	B[0]

24-bit DPI interface connection: set pixel format DPI[2:0]=3'h7

DB23	DB22	DB21	DB20	DB19	DB18	DB17	DB16	DB15	DB14	DB13	DB12	DB11	DB10	DB9	DB8	DB7	DB6	DB5	DB4	DB3	DB2	DB1	DB0
R[7]	R[6]	R[5]	R[4]	R[3]	R[2]	R[1]	R[0]	G[7]	G[6]	G[5]	G[4]	G[3]	G[2]	G[1]	G[0]	B[7]	B[6]	B[5]	B[4]	B[3]	B[2]	B[1]	B[0]

RGB Interface 16/18/24-bit pixel format selection

The Pixel clock (PCLK) is running all the time without stopping, it is used for entering VS, HS, DE and D[23:0] states when there is a rising edge of the PCLK. The PCLK can not be used as the internal clock for other functions of the display module.

Vertical sync hronization (VS) is used to tell when there is received a new frame of the display. This is low enable and its state is read to the display module by a rising edge of the PCLK signal.

Horizontal synchroni zation (HS) is used to tell when there is received a new line of the frame. This is low enable and its state is read to the display module by a rising edge of the PCLK signal .

DE (Data Enable) is used to tell when there is received RGB information that should be transferred on the display. This is a high enable and its state is read to the display module by a rising edge of the PCLK signal.

Part. No	KD035QHFPD154	REV	V1.1	Page 16 of 30
常备库存 Stock For Sale	长期供货 Long Time supply	支持小量 NO MOQ	品种齐全 In Full Range	

D[23:0] are used to tell what is the information of the image that is transferred on the display(When DE= '0' (low) and there is a rising edge of PCLK). D[23:0] can be '0' (low) or '1'(high). These lines are read by a rising edge of the PCLK signal.

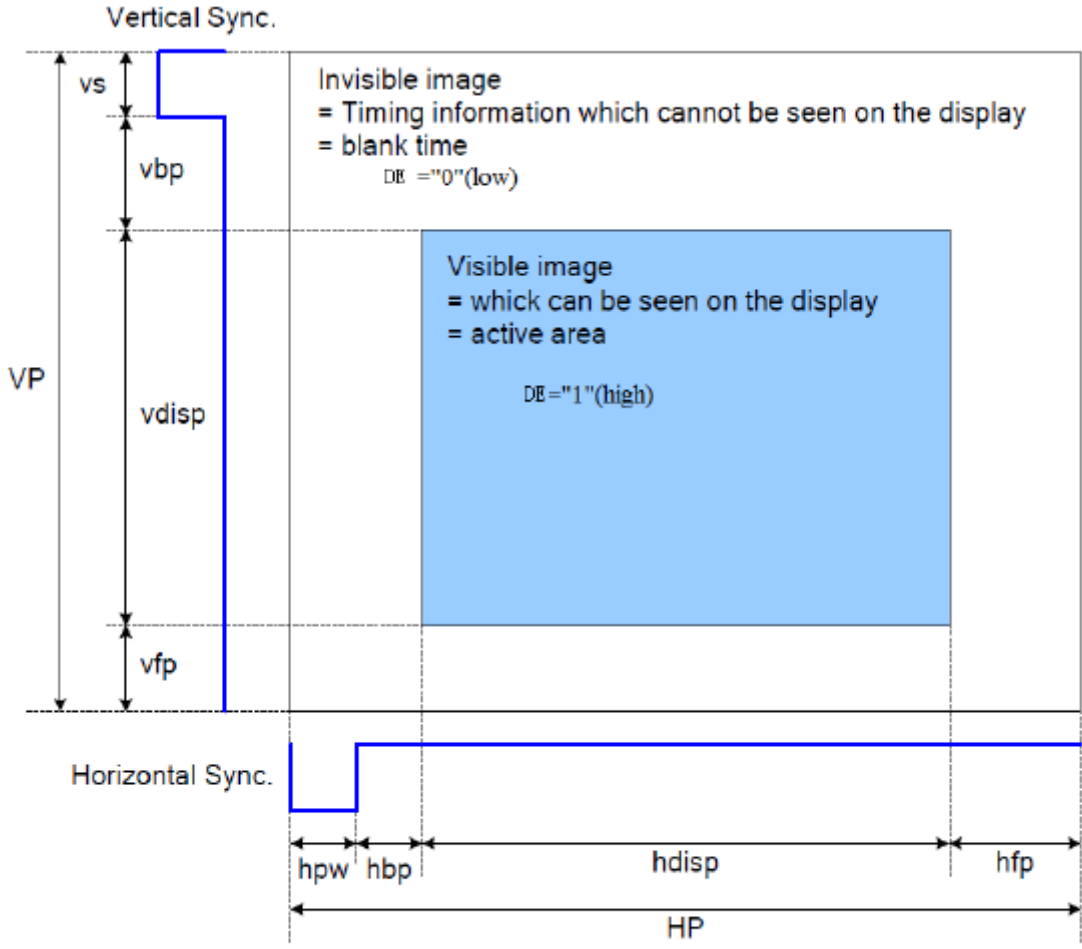

DRAM Access Area by RGB Interface

Part. No	KD035QHFPD154	REV	V1.1	Page 17 of 30
常备库存 Stock For Sale	长期供货 Long Time supply	支持小量 NO MOQ	品种齐全 In Full Range	

6.3 RGB Interface Timing

The timing chart of RGB interface DE mode is shown as follows.

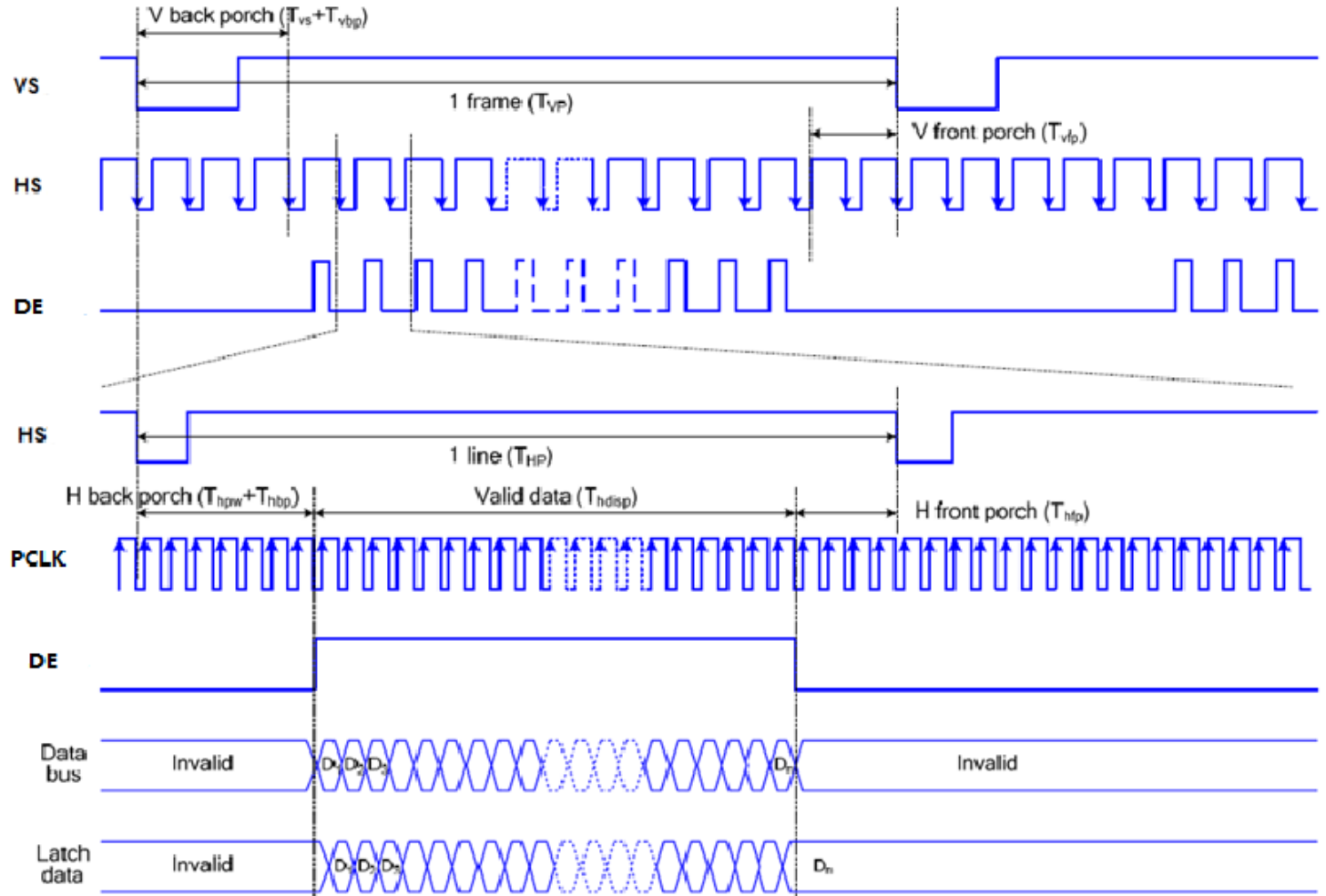

Timing Chart of Signals in RGB Interface DE Mode

Note: The setting of front porch and back porch in host must match that in IC as this mode.

Part. No	KD035QHFPD154	REV	V1.1	Page 18 of 30
常备库存 Stock For Sale	长期供货 Long Time supply	支持小量 NO MOQ	品种齐全 In Full Range	

The timing chart of RGB interface SYNC mode is shown as follows.

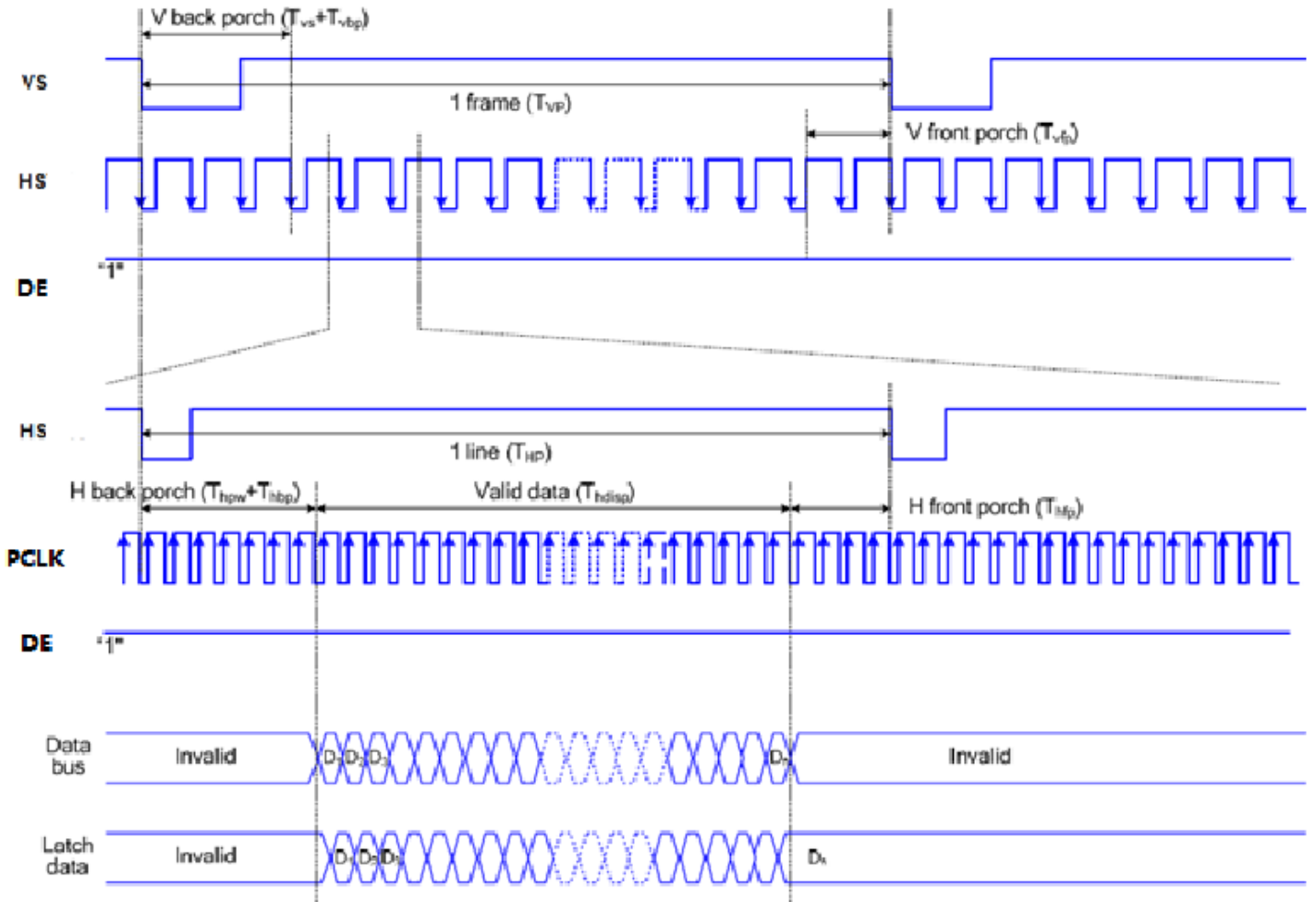

Timing chart of RGB interface SYNC mode

Part. No	KD035QHFPD154	REV	V1.1	Page 19 of 30
常备库存 Stock For Sale	长期供货 Long Time supply	支持小量 NO MOQ	品种齐全 In Full Range	

Below Table provide the timing parameter by external Vertical-cycle
 (Resolution for 720/640 horizontal x 1280 vertical display with Frame-Rate of 60Hz)

Parameters	Symbols	Min.	Typ	Max.	Unit
Horizontal Synchronization	hpw	-	2	-	PCLK
Horizontal Back Porch	hbp	-	42	-	PCLK
Horizontal Front Porch	hfp	-	44	-	PCLK
Hsync+ HBP+ HFP	-	-	88*Note1	-	PCLK
Horizontal Address (Display area)	hdisp	-	720	-	PCLK
Horizontal cycle	-	-	12.703	-	us
Vertical Synchronization	VS	-	2	-	Line
Vertical Back Porch	vbp	-	14	-	Line
Vertical Front Porch	vfp	-	16	-	Line
Vsync+ VBP+ VFP	-	-	32	-	Line
Vertical Address (Display area)	vdisp	-	1280	-	Line
Vertical cycle	-	-	16.66	16.181	ms
Frame-Rate	-	-	60	61.8	Hz

“-” means no limit.

Note : 1. If using Image Process Algorithm, Type value for H-blanking is minimum requirement.

Part. No	KD035QHFPD154	REV	V1.1	Page 20 of 30
常备库存 Stock For Sale	长期供货 Long Time supply	支持小量 NO MOQ	品种齐全 In Full Range	

6.4 Parallel 24/18/16-bit RGB Interface Timing Characteristics

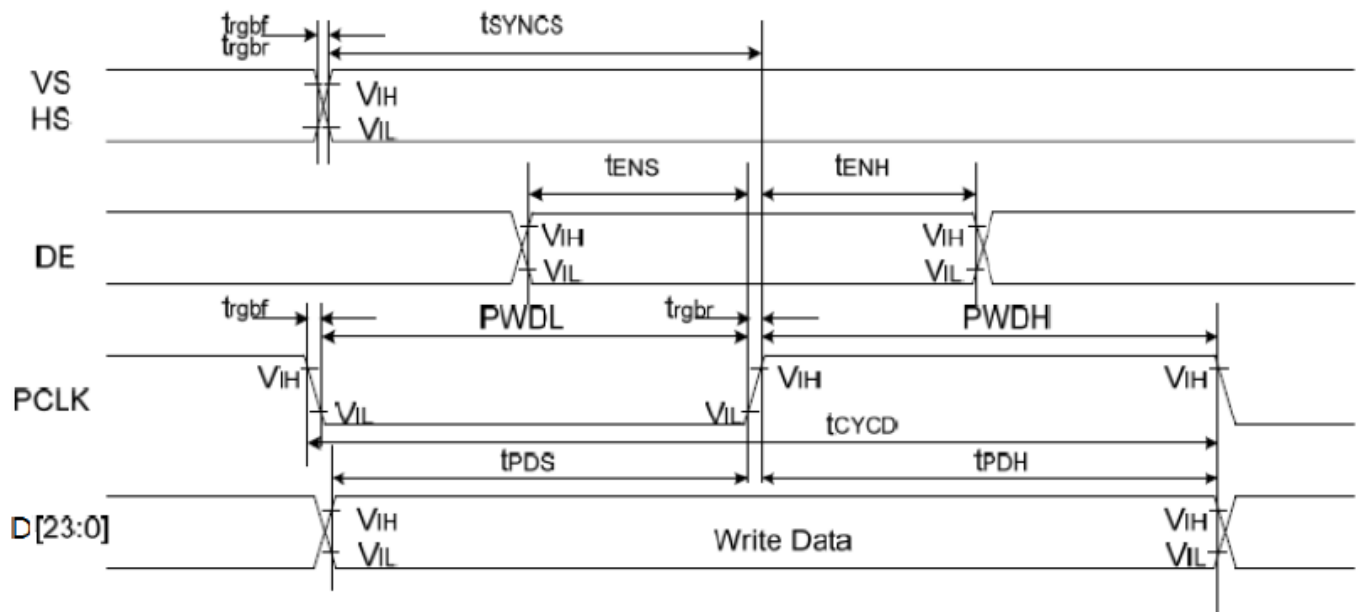

Signal	Symbol	Parameter	min	max	Unit	Description
VS/HS	t_{syncs}	VS/HS setup time	5	-	ns	24/18/16-bit bus RGB interface mode
	t_{synch}	VS/HS hold time	5	-	ns	
DE	t_{ens}	DE setup time	5	-	ns	
	t_{enh}	DE hold time	5	-	ns	
D[23:0]	t_{pos}	Data setup time	5	-	ns	
	t_{pdh}	Data hold time	5	-	ns	
PCLK	$PWDH$	PCLK high-level period	13	-	ns	
	$PWDL$	PCLK low-level period	13	-	ns	
	t_{cycd}	PCLK cycle time	28	-	ns	
	t_{gbr}, t_{gbf}	PCLK, HS, VS rise/fall time	-	15	ns	

Note 1: IOVCC=1.65 to 3.6V, VCI=2.5 to 6V, VSSA=VSS=0V, Ta=-30 to 70°C

Part. No	KD035QHFPD154	REV	V1.1	Page 21 of 30
常备库存 Stock For Sale	长期供货 Long Time supply	支持小量 NO MOQ	品种齐全 In Full Range	

7. LCD Module Out-Going Quality Level

7.1 VISUAL & FUNCTION INSPECTION STANDARD

7.1.1 Inspection conditions

Inspection performed under the following conditions is recommended.

Temperature : 25±5℃

Humidity : 65%±10%RH

Viewing Angle : Normal viewing Angle.

Illumination: Single fluorescent lamp (300 to 700Lux)

Viewing distance:30-50cm

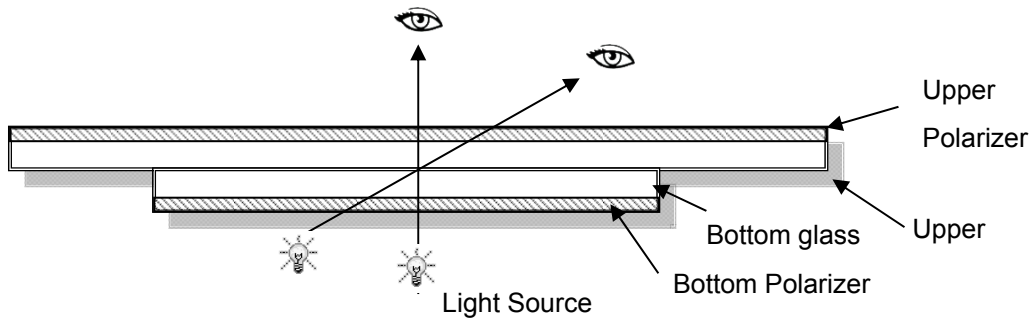

7.1.2 Definition

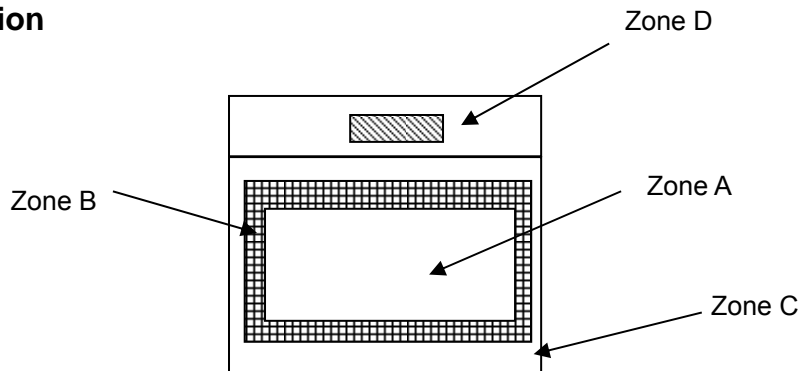

Zone A : Effective Viewing Area(Character or Digit can be seen)

Zone B : Viewing Area except Zone A

Zone C : Outside (Zone A+Zone B) which can not be seen after assembly by customer .)

Zone D : IC Bonding Area

Note:As a general rule ,visual defects in Zone C can be ignored when it doesn't effect product function or appearance after assembly by customer

Part. No	KD035QHFPD154	REV	V1.1	Page 22 of 30
常备库存 Stock For Sale	长期供货 Long Time supply	支持小量 NO MOQ	品种齐全 In Full Range	

7.1.3 Sampling Plan

According to GB/T 2828-2003 ; , normal inspection, Class II

AQL:

Major defect	Minor defect
0.65	1.5

LCD: Liquid Crystal Display , LCM: Liquid Crystal Module,

No	Items to be inspected	Criteria	Classification of defects
1	Functional defects	1) No display, Open or miss line 2) Display abnormally, Short 3) Backlight no lighting, abnormal lighting. etc...	Major
2	Missing	Missing components and etc...	
3	Outline dimension	Overall outline dimension beyond the drawing is not allowed, deformation and etc...	
4	Color tone	Color unevenness, refer to limited sample	Minor
5	Spot/Line defect	Light dot, Dim spot, (Note1) Polarizer Air Bubble, Polarizer accidented spot and etc.	
6	Soldering appearance	Good soldering , Peeling off is not allowed and etc.	
7	LCD/Polarizer	Black/White spot/line, scratch, crack, etc.	

Note1: a) Light dot: Dots appear bright and unchanged in size in which LCD panel is displaying under black pattern.

b) Dim dot: Dots appear dark and unchanged in size in which LCD panel is displaying under pure red, green, blue picture.

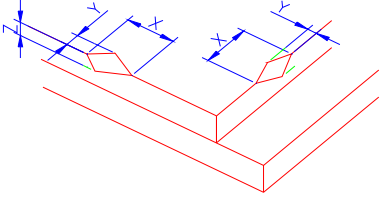
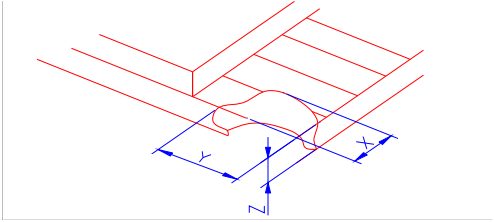
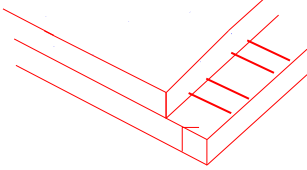

Part. No	KD035QHFPD154	REV	V1.1	Page 23 of 30
常备库存 Stock For Sale	长期供货 Long Time supply	支持小量 NO MOQ	品种齐全 In Full Range	

7.1.4 Criteria (Visual)

Number	Items	Criteria(mm)						
1.0 LCD Crack/Broken NOTE: X: Length Y: Width Z: Height L: Length of ITO, T: Height of LCD	(1) The edge of LCD broken	 <table border="1" data-bbox="756 667 1453 815"> <thead> <tr> <th>X</th> <th>Y</th> <th>Z</th> </tr> </thead> <tbody> <tr> <td>≤3.0mm</td> <td><Inner border line of the seal</td> <td>≤T</td> </tr> </tbody> </table>	X	Y	Z	≤3.0mm	<Inner border line of the seal	≤T
X	Y	Z						
≤3.0mm	<Inner border line of the seal	≤T						
	(2)LCD corner broken	 <table border="1" data-bbox="836 1122 1374 1223"> <thead> <tr> <th>X</th> <th>Y</th> <th>Z</th> </tr> </thead> <tbody> <tr> <td>≤3.0mm</td> <td>≤L</td> <td>≤T</td> </tr> </tbody> </table>	X	Y	Z	≤3.0mm	≤L	≤T
X	Y	Z						
≤3.0mm	≤L	≤T						
	(3) LCD crack	 <p style="text-align: center;">Crack Not allowed</p>						

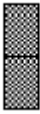
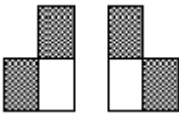

2.0	Spot defect	① light dot (black/white spot , pinhole, stain, etc.)			
	<p style="text-align: center;">$\Phi=(X+Y)/2$</p>	Zone	Acceptable Qty		
		Size (mm)	A	B	C
		$\Phi \leq 0.15$	Ignore		
		$0.15 < \Phi \leq 0.25$	3(distance ≥ 10 mm)		
	$0.25 < \Phi \leq 0.4$	2(distance ≥ 10 mm)			
	$\Phi > 0.4$	0			
		② Dim spot (light leakage、dent、dark spot, etc)			
		Zone	Acceptable Qty		
		Size (mm)	A	B	C
		$\Phi \leq 0.15$	Ignore		
		$0.15 < \Phi \leq 0.25$	3(distance ≥ 10 mm)		
		$0.25 < \Phi \leq 0.4$	2(distance ≥ 10 mm)		
		$\Phi > 0.4$	0		
		③ Polarizer accidented spot			
		Zone	Acceptable Qty		
		Size (mm)	A	B	C
		$\Phi \leq 0.2$	Ignore		
		$0.2 < \Phi \leq 0.5$	2(distance ≥ 10 mm)		
		$\Phi > 0.5$	0		
		④ Polarizer Bubble			
		Zone	Acceptable Qty		
		Size (mm)	A	B	C
		$\Phi \leq 0.2$	Ignore		
		$0.2 < \Phi \leq 0.4$	3(distance ≥ 10 mm)		
		$\Phi > 0.4$	0		

3.0	LCD Pixel defect	<p>Pixel bad points</p> <table border="1"> <thead> <tr> <th data-bbox="539 309 730 360">Item</th> <th data-bbox="730 309 1241 360">Zone A</th> <th data-bbox="1241 309 1492 360">Acceptable Qty</th> </tr> </thead> <tbody> <tr> <td data-bbox="539 360 730 521" rowspan="3">Bright dot</td> <td data-bbox="730 360 1241 412">Random</td> <td data-bbox="1241 360 1492 412">N≤2</td> </tr> <tr> <td data-bbox="730 412 1241 463">2 dots adjacent</td> <td data-bbox="1241 412 1492 463">N≤0</td> </tr> <tr> <td data-bbox="730 463 1241 521">3 dots adjacent</td> <td data-bbox="1241 463 1492 521">N≤0</td> </tr> <tr> <td data-bbox="539 521 730 689" rowspan="3">Dark dot</td> <td data-bbox="730 521 1241 573">Random</td> <td data-bbox="1241 521 1492 573">N≤2</td> </tr> <tr> <td data-bbox="730 573 1241 631">2 dots adjacent</td> <td data-bbox="1241 573 1492 631">N≤0</td> </tr> <tr> <td data-bbox="730 631 1241 689">3 dots adjacent</td> <td data-bbox="1241 631 1492 689">N≤0</td> </tr> <tr> <td data-bbox="539 689 730 1003">Distance</td> <td data-bbox="730 689 1241 1003"> 1. Minimum Distance Between Bright dots. 2. Minimum Distance Between dark dots 3. Minimum Distance Between dark and bright dot. </td> <td data-bbox="1241 689 1492 1003">5mm</td> </tr> <tr> <td colspan="2" data-bbox="539 1003 1241 1055">Total bright and dark dot</td> <td data-bbox="1241 1003 1492 1055">N≤4</td> </tr> </tbody> </table> <p>Note:</p> <p>A) Bright dot: Dots appear bright and unchanged in size in which LCD panel is displaying under black pattern.</p> <p>B) Dark dot: Dots appear dark and unchanged in size in which LCD panel is displaying under pure red, green, blue picture.</p> <p>C) 2 dot adjacent = 1 pair = 2 dots</p> <p>Picture:</p> <div style="display: flex; justify-content: space-around; align-items: flex-start;"> <div style="text-align: center;">  <p>2 dot adjacent</p> </div> <div style="text-align: center;">  <p>2 dot adjacent</p> </div> </div> <div style="display: flex; justify-content: space-around; align-items: flex-start; margin-top: 20px;"> <div style="text-align: center;">  <p>2 dot adjacent (vertical)</p> </div> <div style="text-align: center;">  <p>2 dot adjacent (slant)</p> </div> </div>	Item	Zone A	Acceptable Qty	Bright dot	Random	N≤2	2 dots adjacent	N≤0	3 dots adjacent	N≤0	Dark dot	Random	N≤2	2 dots adjacent	N≤0	3 dots adjacent	N≤0	Distance	1. Minimum Distance Between Bright dots. 2. Minimum Distance Between dark dots 3. Minimum Distance Between dark and bright dot.	5mm	Total bright and dark dot		N≤4
Item	Zone A	Acceptable Qty																							
Bright dot	Random	N≤2																							
	2 dots adjacent	N≤0																							
	3 dots adjacent	N≤0																							
Dark dot	Random	N≤2																							
	2 dots adjacent	N≤0																							
	3 dots adjacent	N≤0																							
Distance	1. Minimum Distance Between Bright dots. 2. Minimum Distance Between dark dots 3. Minimum Distance Between dark and bright dot.	5mm																							
Total bright and dark dot		N≤4																							

4.0	Line defect (LCD /Polarizer backlight black/white line, scratch, stain)  W: width, L : length N : Count	<table border="1"> <tr> <th rowspan="2">Width(mm)</th> <th rowspan="2">Length(m)</th> <th colspan="3">Acceptable Qty</th> </tr> <tr> <th>A</th> <th>B</th> <th>C</th> </tr> <tr> <td>$\Phi \leq 0.05$</td> <td>Ignore</td> <td colspan="2">Ignore</td> <td rowspan="3">Ignore</td> </tr> <tr> <td>$0.05 < W \leq 0.06$</td> <td>$L \leq 4.0$</td> <td colspan="2">$N \leq 3$</td> </tr> <tr> <td>$0.06 < W \leq 0.08$</td> <td>$L \leq 3.0$</td> <td colspan="2">$N \leq 2$</td> </tr> <tr> <td>$W > 0.08$</td> <td colspan="4">Define as spot defect</td> </tr> </table>	Width(mm)	Length(m)	Acceptable Qty			A	B	C	$\Phi \leq 0.05$	Ignore	Ignore		Ignore	$0.05 < W \leq 0.06$	$L \leq 4.0$	$N \leq 3$		$0.06 < W \leq 0.08$	$L \leq 3.0$	$N \leq 2$		$W > 0.08$	Define as spot defect			
		Width(mm)			Length(m)	Acceptable Qty																						
			A	B		C																						
		$\Phi \leq 0.05$	Ignore	Ignore		Ignore																						
		$0.05 < W \leq 0.06$	$L \leq 4.0$	$N \leq 3$																								
$0.06 < W \leq 0.08$	$L \leq 3.0$	$N \leq 2$																										
$W > 0.08$	Define as spot defect																											
5.0	Electronic Components SMT.	Not allow missing parts, solderless connection, cold solder joint, mismatch, The positive and negative polarity opposite																										
6.0	Display color & Brightness.	1. Color: Measuring the color coordinates, The measurement standard according to the datasheet or samples. 2. Brightness: Measuring the brightness of White screen, The measurement standard according to the datasheet or Samples.																										
7.0	LCD Mura/Waving/ Hot spot	Not visible through 5% ND filter in 50% gray or judge by limit sample if necessary.																										

Criteria (functional items)

Number	Items	Criteria (mm)
1	No display	Not allowed
2	Missing segment	Not allowed
3	Short	Not allowed
4	Backlight no lighting	Not allowed

8. Reliability Test Result

Item	Condition	Inspection after test
High Temperature Operating	85°C,96H	Inspection after 2~4hours storage at room temperature, the sample shall be free from defects: 1.Air bubble in the LCD; 2.Non-display; 3.Missing segments/line; 4.Glass crack; 5.Current IDD is twice higher than initial value.
Low Temperature Operating	-30°C, 96HR	
High Temperature Storage	85°C, 96HR	
Low Temperature Storage	-30°C, 96HR	
High Temperature & High Humidity Operating	+60°C, 90% RH ,96 hours.	
Thermal Shock (Non-operation)	-30°C,30 min ↔ +80°C,30 min, Change time:5min 20CYC.	
ESD test	C=150pF, R=330,5points/panel Air:±8KV, 5times; Contact:±6KV, 5 times; (Environment: 15°C~35°C, 30%~60%).	
Vibration (Non-operation)	Frequency range:10~55Hz, Stroke:1.5mm Sweep:10Hz~55Hz~10Hz 2 hours for each direction of X.Y.Z. (6 hours for total) (Package condition).	
Box Drop Test	1 Corner 3 Edges 6 faces,80cm(MEDIUM BOX)	

Remark:

- 1.The test samples should be applied to only one test item.
- 2.Sample size for each test item is 5~10pcs.
- 3.For Damp Proof Test, Pure water(Resistance > 10MΩ) should be used.
- 4.In case of malfunction defect caused by ESD damage, if it would be recovered to normal state after resetting, it would be judged as a good part.
- 5.Failure Judgment Criterion: Basic Specification, Electrical Characteristic, Mechanical Characteristic, Optical Characteristic.

Part. No	KD035QHFPD154	REV	V1.1	Page 28 of 30
常备库存 Stock For Sale	长期供货 Long Time supply	支持小量 NO MOQ	品种齐全 In Full Range	

9. Cautions and Handling Precautions

9.1 Handling and Operating the Module

(1) When the module is assembled, it should be attached to the system firmly.

Do not warp or twist the module during assembly work.

(2) Protect the module from physical shock or any force. In addition to damage, this may cause improper operation or damage to the module and back-light unit.

(3) Note that polarizer is very fragile and could be easily damaged. Do not press or scratch the surface.

(4) Do not allow drops of water or chemicals to remain on the display surface.

If you have the droplets for a long time, staining and discoloration may occur.

(5) If the surface of the polarizer is dirty, clean it using some absorbent cotton or soft cloth.

(6) The desirable cleaners are water, IPA (Isopropyl Alcohol) or Hexane.

Do not use ketene type materials (ex. Acetone), Ethyl alcohol, Toluene, Ethyl acid or Methyl chloride. It might permanent damage to the polarizer due to chemical reaction.

(7) If the liquid crystal material leaks from the panel, it should be kept away from the eyes or mouth. In case of contact with hands, legs, or clothes, it must be washed away thoroughly with soap.

(8) Protect the module from static; it may cause damage to the CMOS ICs.

(9) Use finger-stalls with soft gloves in order to keep display clean during the incoming inspection and assembly process.

(10) Do not disassemble the module.

(11) Protection film for polarizer on the module shall be slowly peeled off just before use so that the electrostatic charge can be minimized.

(12) Pins of I/F connector shall not be touched directly with bare hands.

(13) Do not connect, disconnect the module in the "Power ON" condition.

9.2 Storage and Transportation.

(1) Do not leave the panel in high temperature, and high humidity for a long time.

It is highly recommended to store the module with temperature from 0 to 35 °C and relative humidity of less than 70%

(2) Do not store the TFT-LCD module in direct sunlight.

(3) The module shall be stored in a dark place. When storing the modules for a long time, be sure to adopt effective measures for protecting the modules from strong ultraviolet radiation, sunlight, or fluorescent light.

(4) It is recommended that the modules should be stored under a condition where no condensation is allowed. Formation of dewdrops may cause an abnormal operation or a failure of the module.

In particular, the greatest possible care should be taken to prevent any module from being operated where condensation has occurred inside.

(5) This panel has its circuitry FPC on the bottom side and should be handled carefully in order not to be stressed.

Part. No	KD035QHFPD154	REV	V1.1	Page 29 of 30
常备库存 Stock For Sale	长期供货 Long Time supply	支持小量 NO MOQ	品种齐全 In Full Range	

10. Packing

---TBD-----

Part. No	KD035QHFPD154	REV	V1.1	Page 30 of 30
	常备库存 Stock For Sale	长期供货 Long Time supply	支持小量 NO MOQ	品种齐全 In Full Range